

05. Tavoline studimi (TS.2)

Tavoline studimi

Specifikime:

Permase: Gjeresia 83-85 cm, Thellesia 50-52 cm, Lartesia 75-79cm

Materiali: Material druri e perpunuar me melamine te lustruar

Permban: 1 sirtar horizontal

Kembezat: Druri

Ngjyre: Druri (lisi/arre)/te bardhe

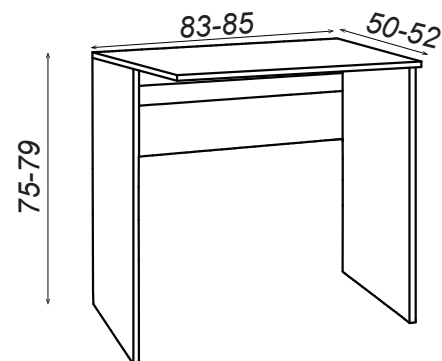

06. Tavoline studimi (TS.3)

Tavoline studimi

Specifikime:

Permase: Gjeresia 68-72 cm, Thellesia 45-52 cm, Lartesia 74-75 cm

Materiali: Material druri e perpunuar me melamine te lustruar

Kembezat: Druri

Ngjyre: Druri (lisi/arre)/te bardhe

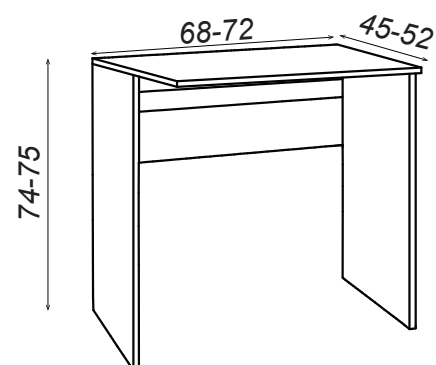

05. Tavoline studimi salle (TSS.1)

Tavoline studimi salle

Specifikime:

Permasa:

Gjeresia 120 cm, Thellesia 60 cm, Lartesia 75 cm

Materiali:

Pjesa e përparme: Plastikë ABS, melaminë, metal, dërrasë copëzash druri, Pjesa e sipërme: Plastikë ABS, melaminë, dërrasë copëzash druri

Struktura:

Metal

Kembezat:

Metalike

Ngjyre:

Druri (lisi/arre)

Pesha:

12kg

Ngarkesa:

40 kg

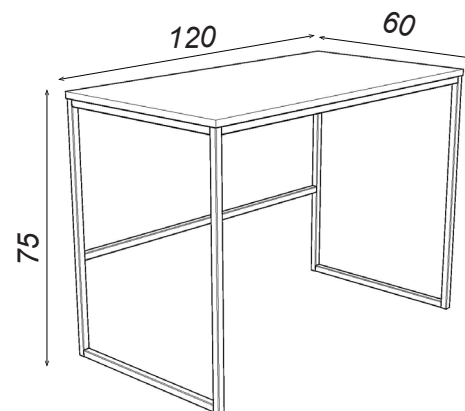

06. Tavoline zyre kendore (TZ.1)

Tavoline zyre kendore

Specifikime:

Permasa:

Gjeresia 147-165 cm, Thellesia 107-113 cm, Lartesia 75-77 cm

Materiali:

Melamine e lustruar

Struktura:

Kornize metalike ngjyre te zeze, si dhe syprine druri ,melamine e lustruar

Ngjyre:

Druri (lisi,arre)

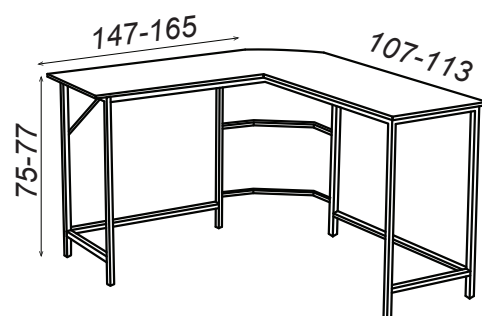

07. Tavoline zyre lineare (TZ.2)

Tavoline zyre lineare

Specifikime:

Permasa:	Gjeresia 120-130 cm, Thellesia 50-55 cm, Lartesia 75 cm
Materiali:	Material druri e perpunuar me melamine te lustruar/ HDF
Permban:	2 Sirtarë anësorë
Kembezat:	Druri
Ngjyre:	Druri (lisi)/te bardhe

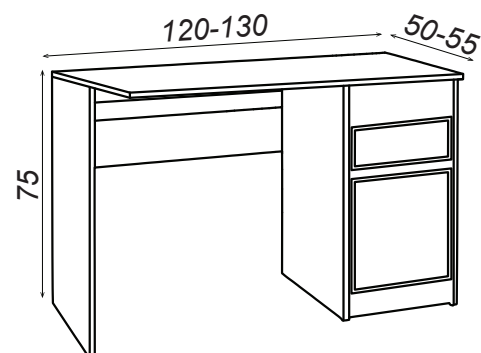

08. Tavolina ngenie (TN.1)

Tavolina ngenie

Specifikime:

Permasa: Gjatesia 110-120 cm, Gjeresia 70-75 cm, Lartesia 75 cm

Forma: Drejtkendore

Materiali: Melamine/ Dru pishe

Materiali: Melamine/Dru pishe

Ngjyra: Druri (lisi/arre)

Pesha: 15 kg

Ngarkesa maksimale: 60 kg

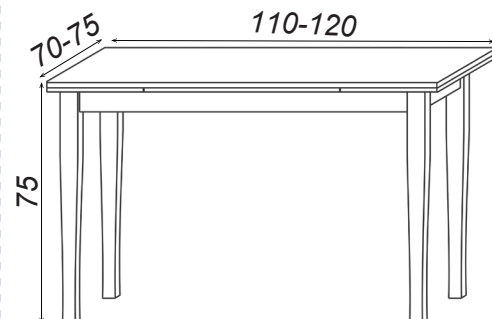

09.

Tavoline mesi (TM.1)

Tavoline mesi

Specifikime:

Permasa: Rreze: Ø60-Ø75, Lartesia 45-52 cm
 Materiali: Struktura Hekur/Celiku, Syprine celiku
 Ngjyre: E zeze

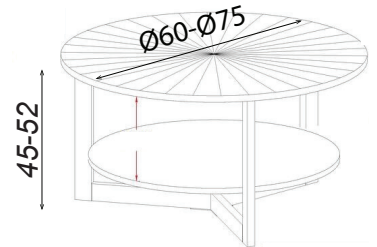

10.

Karrige studimi (KS.1)

Karrige studimi

Specifikime:

Permasa: Gjeresia 51.5-61 cm, Thellesia 58-60 cm,
 Lartesia e mbeshtetese: 88-107cm
 Materiali: Struktura metalike, Mbeshtetese rrjetezuar Sfungjer
 PP (Polipropilen), drui shtresuar, poliester, celik
 Ngjyre: E zeze

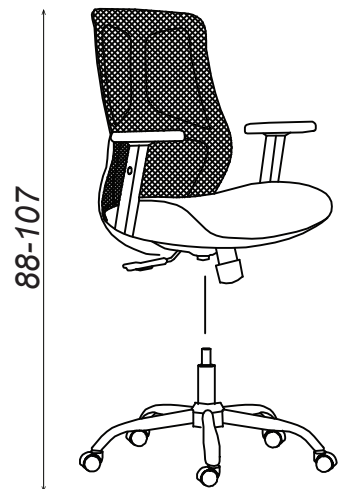

11.

Karrige ngrenie (KN.1)

Karrige ngrenie

Specifikime:

Permasa: Gjeresia 55-58 cm, Thellesia 40.6-54 cm,
Lartesia e mbeshtetese 71-88 cm

Materiali i veshjes: Struktura metalike, tapiceri tekstili/ PP (Polipropilen),
Pa krahe

Materiali i kembeve: Kembe druri

Ngjyre: E zeze



12.

Karrige statike (KST.1)

Karrige statike

Specifikime:

Permasa: Gjeresia 52-59 cm, Thellesia 46-54 cm,
Lartesia e mbeshtetese 81-90 cm

Materiali: Tapiceri PU, Kembe druri/ Sfungjer, dru i shtresuar,
Kembe celiku/Polipropilen, hekur

Ngjyre: Gri/ Te zeze, me Kembe te zeza/Kafe

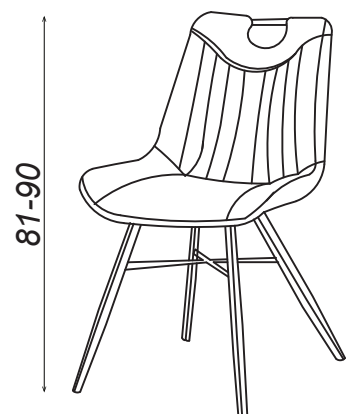

13. Komodine me sirtare (KO.1)

Komodine me sirtare

Specifikime: Gjeresia 41-55 cm, Thellesia 44-55 cm, Lartesia 55-59 cm
Permasa:

Materiali: Melamine e lustruar
Permban: 2 sirtar + shina sirtari me ndalese
Manteshat: Metalike
Kembezat: Druri/metalike
Doreza: Druri/metalike me ngjyre gri/te zeza
Ngjyre: Te bardhe/druri (lisi/arre)

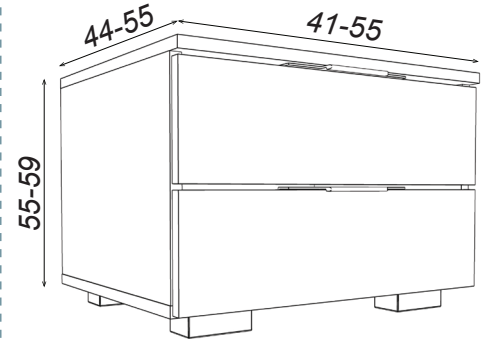

14. Dollap rrobash (DO.1)

Dollap rrobash

Specifikime: Gjeresia 80 cm, Thellesia 47-52 cm, Lartesia 187-205 cm
Permasa: 187-205 cm
Materiali: HDF (Derrase copezash druri me densitet te larte), Melamine, Derrase copezash druri

Dyert: Derrase copash druri ngjyre druri dhe te bardhe
Sirtari:

Ballorja: Derrase copezash druri,
Baza: HDF ose druri, Anesoret: Derrase copezash druri, Pjesa e pasme: Derrase copezash druri

Menteshat: Metal
Permban: 1 shufer per varje, 2 dyer, 2 sirtar (me raste)
Menteshat: Metal
Ngjyre: Druri dhe e bardhe

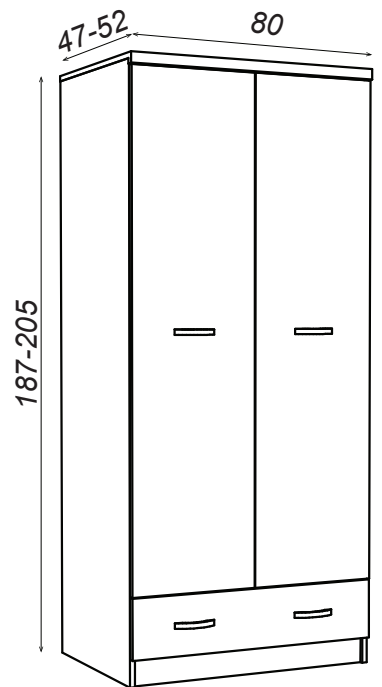

15.

Dollap rrobash (DO.2)

Dollap rrobash

Specifikime:

Permase: Gjeresia 70 cm, Thellesia 51-55 cm, Lartesi 192-200 cm

Materiali:

Melamine e lustruar

Dyert:

Melamine e lustruar, ngjyre e bardhe/e zeze.

Derrase copezash druri, ngjyre e bardhe

Manteshat:

Metalike

Numri i dyerve:

2 dyer

Numri i rafteve:

2 rafte

Kembezat:

Plastike

Ngjyre:

Te bardhe/druri (lis/arre)

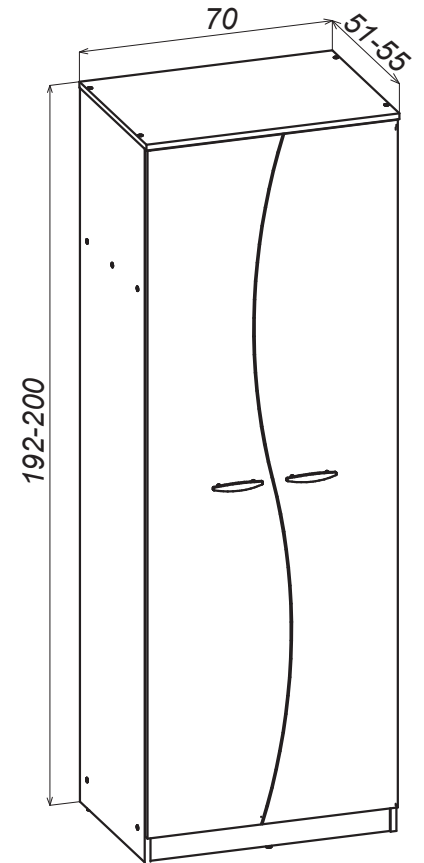

16.

Rafte librash zyre (RZ.1)

Rafte librash zyre

Specifikime:

Permase: Gjeresia 70-80 cm, Thellesia 29-38 cm, Lartesi

180-215 cm

Materiali: HDF (Derrase copezash druri me densitet te larte), laminat me presion te larte, derrase copezash druri

Permban:

(te crregullta)

5-6 ndarje horizontale dhe 2-3 ndarje vertikale

Ngjyre:

Lisi/arre

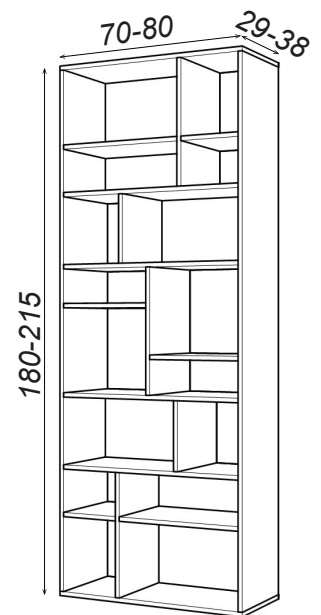

17. Raft magazinimi per depo (RD.1)

Raft magazinimi per depo

Specifikime: Gjeresia 88-110 cm, Thellesia 34-50 cm, Lartesi
Permasa: 180-200 cm

Materiali: Struktura metalike me montim te nderthurur
Raft metalik
Tipi: Ndarje te kombinuara 4+ ndarje horizontale + ndarje
Ndarje: vertikale
Ngjyre: Silver/metalike dhe e zeze

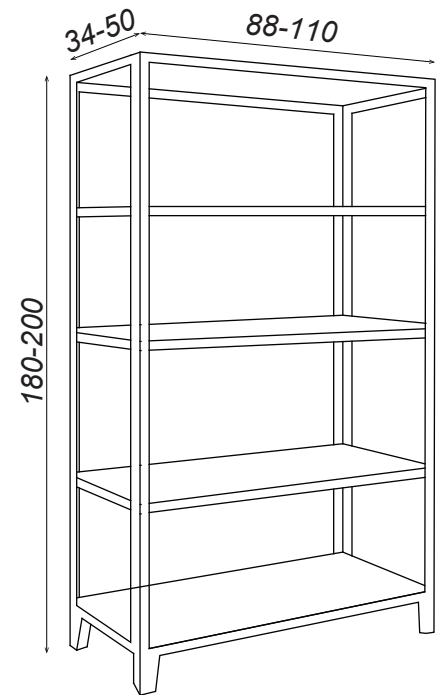

18. Dollap dhome zhveshje (RDZ.1)

Dollap dhome zhveshje

Specifikime: Gjeresia 90 cm, Thellesia 45 cm, Lartesia 185-215 cm
Permasa:

Materiali: Struktura metalike
Raft metalik
Tipi: 3 Kanata individuale me celesa + ndarje + varese + kembe
Ndarje:
Ngjyre: Metalike/gri

Pershkrimi:
Dollap metalik per dhoma zhveshjeje, me kanata me celes+ndarje dhe varese.



19.

Raft librash mural (RM.1)

Raftelibrash mural

Specifikime:

Permase: Gjeresia 137.5-150 cm, Thellesia 21-22 cm, Lartesia 22-24 cm

Materiali: Sergjen : MDF, Dru ,Struktura: metalike

Ngjyre: Druri e hapur/Lisi/e bardhe

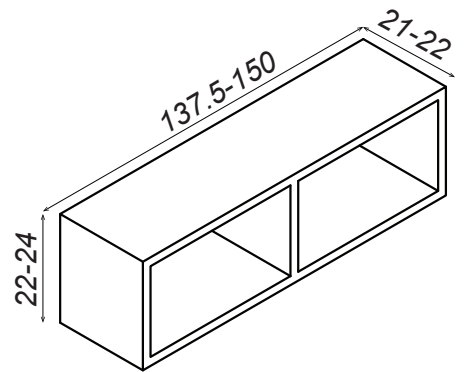

20.

Stol (S.1)

Stol druri

Specifikime:

Permase: Gjeresia 70-110 cm, Thellesia 26-30 cm, Lartesi 31-43 cm

Materiali: Dru plepi/Dru eukalipti/dru i thjeshte

Ngjyre: Druri (lisi/arre)

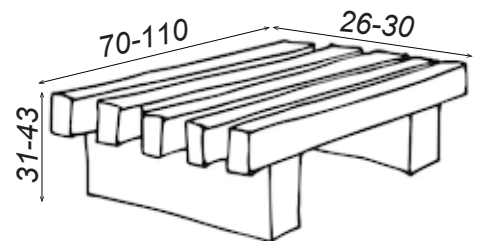

21. Divan 3-vendesh (DI.1)

Divan 3-vendesh

Specifikime:

Permase: Gjeresia 181-214 cm, Thellesia 80-95 cm,
Lartesia e uleses 45, Lartesia e mbeshteteses: 80 cm

Materiali: Struktura metali, Tapiceri tekstili/Sfungjer, poliester

Kembezat: Metalike ngjyre gri/ Druri

Ngjyre: Gri e hapur/Gri e erret

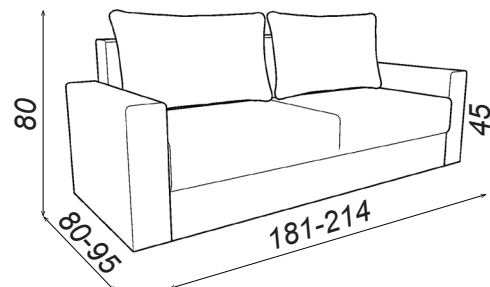

22. Ndricules tavoline (ND.1), ne tavolinen e dhomes se gjumit

Ndricules tavoline (ND.1), ne tavolinen e dhomes se gjumit

Specifikime:

Permase: Lartesia 42-53 cm

Materiali: Struktura metali/celiku, plastike

Ngjyre: Te bardhe, te zeze, e kuqe



23.

Perde + Aksesore

Perde + Aksesore

Specifikime:

Permasa: Gjeresia 140-150 cm, Gjatesia 240-260
 Materiali: 50% Pambuk, 10% viskoz, 25% Poliester, 15% Lino, Poliester, Lekure e jthyer artificiale
 Ngjyre: Bezhe, gri e erret/e hapur
 Dizanji: Dizanji i thjeshte, me pala te palosura/valezuara

Shufer per perde

Permasa: Diameter 20 - 19/16 - 17/20, Gjatesia 160-240
 Ngjyra: Argjend/e zeze
 Materiali: Metalik/druri

Suport per shufer

Ngjyra: Argjend/e zeze
 Materiali: Metalik/druri

Shenim: Per permasat e perdeve, te behet matja e dritareve ne vend per secilin objekt.



24.

Krevat Egzaminimi (KE.1)

Krevat Egzaminimi

Specifikime:

Permasa: Gjeresia 185-190 cm, Thellesia 60-65 cm, Lartesia 60-68 cm

Pesha maksimale: 150 kg

Ngjyre: E bardhe, kafe, te zeze

Ngjyre: Te bardhe, kafe, te zeze

Mekanizem per mbajtjen e rrulonit.

